

RCDFJ-□T 系列强迫油循环自卸式电磁除铁器

:

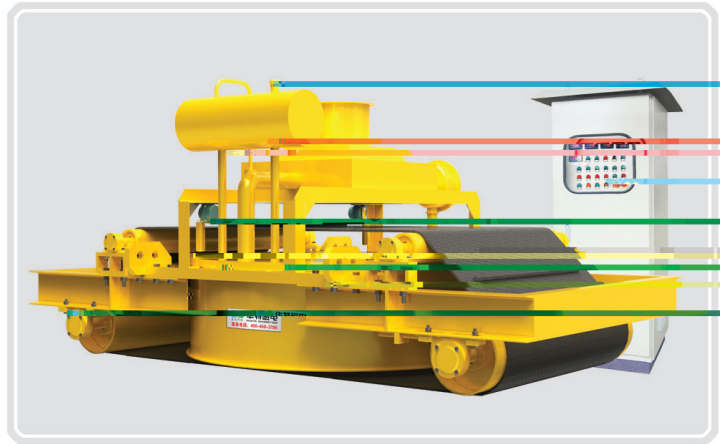

900Gs 1200Gs 1500Gs

1750Gs 2000Gs 2250Gs 2500Gs

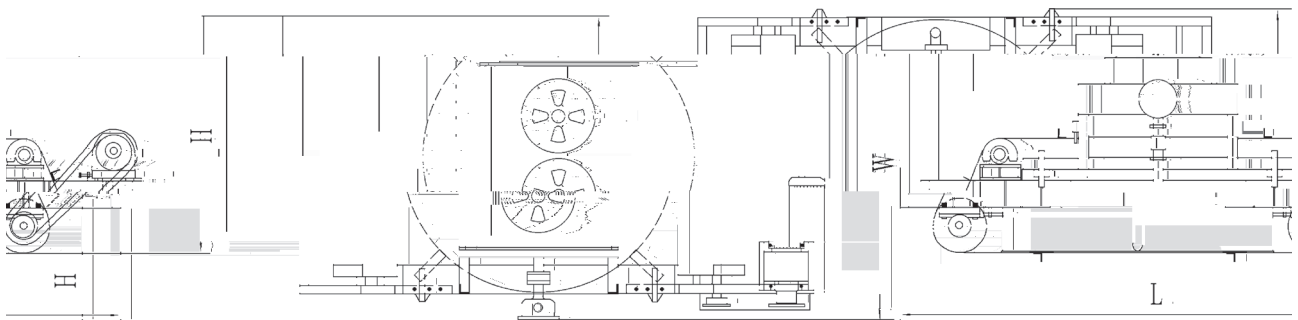

:

: 200610044750. 4

: ZL200620085563. 6

(50)

(50)

		mm	h mm	mT	KW	KW	Lx Wx H mm	m/s	kg
RCDFJ- 10	T1	1000	300	90	10	0.25	2960x 1700x 1480	5.8	
	T2			120	13	0.25	3170x 1830x 1570		
	T3			150	21	0.25	3170x 1830x 1550		
RCDFJ- 12	T1	1200	350	90	12	0.25	3250x 2000x 1520		
	T2			120	20	0.25			
	T3			150	33	0.55			
RCDFJ- 14	T1	1400	400	90	20	0.25			
	T2			120	33	0.55			
	T3			150	35	0.55			
RCDFJ- 16	T1	1600	450	90	33	0.55			
	T2			120	35	0.55			
	T3			150	40	0.55			
	T4			175	45	0.55			
	T5			200	55	1.1			
	T6			225	85	1.1			
	T7			250	95	2x 0.55			
RCDFJ- 18	T1	1800	500	90	26	0.55			
	T2			120	40	0.55			
	T3			150	46	0.55			
	T4			175	56	1.1			
	T5			200	75	2x 0.55			
	T6			225	90	1.1			
	T7			250	107	2x 0.55			
RCDFJ- 20	T1	2000	550	90	40	0.55			
	T2			120	46	0.55			
	T3			150	51	1.1			
	T4			175	65	2x 0.55			
	T5			200	90	2x 0.55			
	T6			225	104	2x 0.55			
	T7			250	125	2x 0.55			
RCDFJ- 22	T1	2200	600	90	39	0.55			
	T2			120	42	0.55			
	T3			150	60	1.1			
	T4			175	100	2x 0.55			
	T5			200	121	2x 0.55			
	T6			225	153	2x 0.55			
	T7			250	176	2x 0.55			
RCDFJ- 24	T1	2400	650	90	40	0.55			
	T2			120	46	0.55			
	T3			150	105	2x 0.55			
	T4			175	120	2x 0.55			
	T5			200	150	2x 0.55			
	T6			225	180	2x 0.75			
	T7			250	200	2x 1.1			